

COMPLETE STEERING SYSTEMS

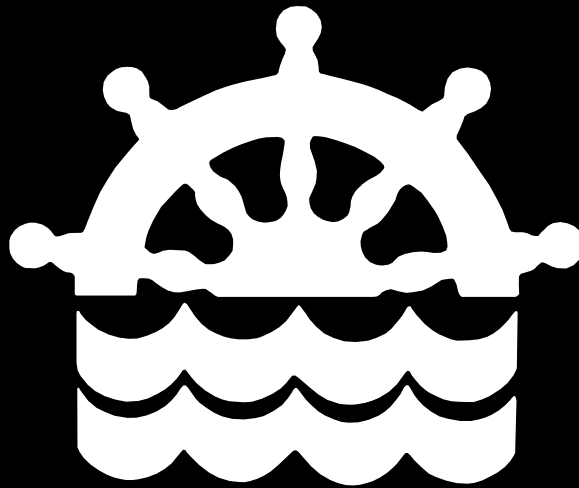

Scan-Steering

Excellent Navigation

a2:scan

SCAN-STEERING

History

Scan-Steering was founded in 1960. Today Scan-Steering is one of the leading manufactures of complete steering systems, for several types of vessels in the world. We have a wide range of hydraulic end electronic equipment consisting of:

- Magnetic compass
- Gyro compass
- Repeaters
- Autopilots
- Rudder control systems
- Hydraulic steering gear
- Power units
- Computer systems
- Accessories

Scan-Steering has always been ahead of their competitors when it comes to developing new technology and total steering systems, and dealing with only one supplier will benefit you in several ways:

- Total compatibility
- Easy instalation
- Easy maintenance
- Easy service
- Quick support
- Tested systems

The steering system

Today's modern vessels require the steering system of the future, which can help reduce the cost of maintenance and increase fuel efficiency. Scan-Steering has more than 40 years of experience in making and installing special steering systems for awide variety of vessels.

The systems are made for one, two, three or more rudders and the multi rudder system can be electronic or mechanical synchronized. All of our systems are made according to IMO, SOLAS and are build to fit the restrictions of any classification authority.

The steering gears are designed with one or two cylinderes which gives a very high degree of safty and reliability. It can be provided with a support ball bearing, a spherical rudder carrier bearing, or other types of bearings.

The steering is supplied with a handhydraulic wheel pump (axial piston pump), for hand and emergency steering. The wheel pump can be delivered for panel-mounting, but can also be built into a steering column. All our hydraulic pumps can be created to fit your demands. All necessary valves and fittings are supplied according to classification requirements.



Scan-Steering
Excellent Navigation

Danish craftmanship

-combined with the latest technology

Scan-Steering has continuously been working on improvement in quality and performance of all parts of the steering systems produced by the company.

The latest improvement has been made in the sealing components of the steering gears. The U-gaskets and scraper rings that were used before, have been replaced by the newest technology in teflon gaskets.

This gives a lot of benefits such as great reduction in the normal wear on piston rods, reduced risk of leaks, very long life-time of the gaskets, which means that no maintenance is required.

With this latest improvement the steering gear will work for a long period of time, without requiring repairs or major overhaul, as long as the required lubrication is made according to manufacturer's instructions.

Scan-Steering has a very flexible production line, and can make steering gears and systems according to requirements. Including high shock resistant anti-magnetic steering gear made in salt water resistant stainless steel and special construction for navy boats.

Scan-Steering is capable of delivering steering gears with capacity up to 1.000 KNm for single or twin rudder vessels. For twin rudder vessels there are possibilities of mechanical synchronization by means of a connecting rod or electronic synchronization of rudders, where connection rod is not possible to use, such as catamarans etc. in which case the company's unique double electronic rudder control system is used.

The electronic rudder control is extremely accurate, thanks to the electronic rudder angle transmitter, which has now been proven unsurpassed for nearly 10 years. The transmitter operates without potentiometer which means that there is no mechanical wear and in many cases the rudder transmitter(s) will last for the lifetime of the vessel.

All Scan-Steering's steering systems are made to meet the requirements of the various classification authorities, this means that all steering gears etc. are made from approved materials and are constructed, assembled, and tested in accordance with the rule and regulations of all major classification authorities. Consequently all systems can be delivered with certificate according to customer's requirement.

For a complete referencelist please contact us.



STEERING GEAR MT-0.5-100 T.M.



MT-0.5-100 T.M.

Hand and electro-hydraulic steering gears ranging from 0.5-100 T.M. The steering gear is suitable for one, two or more rudders, either with connection bar or electrical synchronizing. The steering gear is supplied with:

- Wheel pump
- Non-return valve
- Flexible hoses
- Base plate with support bearing
- Tiller with keyway and bolts
- All necessary valves and fittings.



Scan-Steering
Excellent Navigation

Hydraulic gear

All our parts are approved by every major classification societies



PSU-50

The new low noise, soft control, electro-hydraulic power steering unit. Complete with:

- Electrical motor
- Oil pump
- Non-return valve
- Filter unit
- Counter balance
- Vacuummeter for filter control
- Pressure control manometer



PSU 1.5 kW

Single pump unit. Electrical motors squirrel cage type. Current and frequency according to customer's requirement. IP55 protection, insulation class F, included in the hydraulic tank and homologous accessories, such as gauge glasses, low oil level switch, temperature- and pressure switches, valves and fittings. Electrical motor is to drive one gear wheel pump thru an elastic coupling. Pump units can be ordered with lock alarm and class certificate from any classification society.



PSU 2x60 kW

Dual pump unit. Build on double tank, separated by internal wall. Two identical electrical motors squirrel cage type. Current and frequency according to customer's requirement. IP55 protection, insulation class F, included in the hydraulic tank and homologous accessories, such as gauge glasses, low oil level switch, temperature- and pressure switches, valves and fittings. Each motor is to drive one gear wheel pump thru an elastic coupling. Pump units can be ordered with lock alarm and class certificate from any classification society.

P-10

Hydraulic oil pump, complete with mounting plate, build in flow control and safety valve. Adjustable oil flow.

Driven by V-belt from main engine.



The safety valve and flow control ensure a constant speed of the rudder, regardless the speed of the main engine. Standart version for clock wise rotation. When counter-clock wise is needed order P-5.

PV-20/30

Seperate control valve unit.

Complete with mounting plate, set of 24VDC solenoid, control valve, filter unit and non-return valve.

Maximum work area: 25L/min or 50L/min.



Motor starters

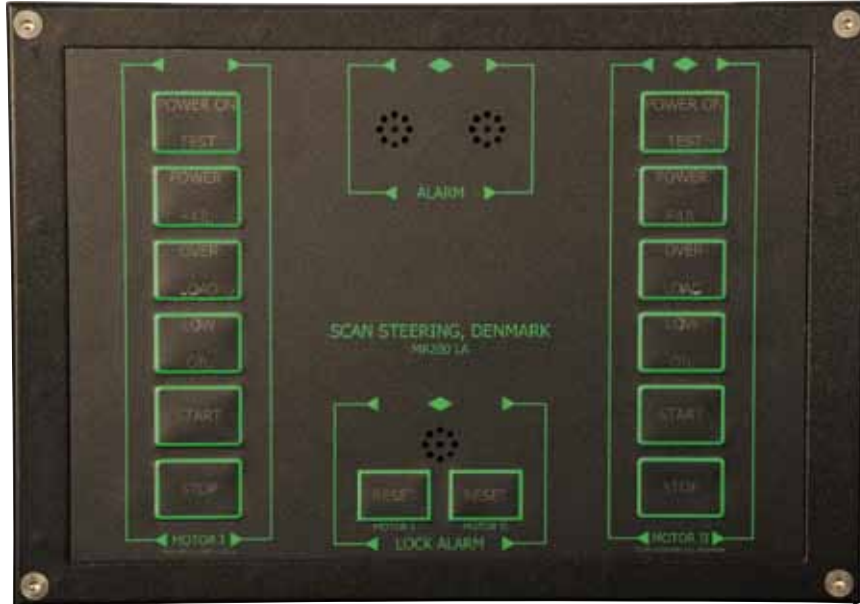

MR-200 LA

Remote control for MS-2 motorstarter.

For mounting on bridge. Alarms for:

- Start/stop
- Test
- Power failure
- Low oil
- Overload
- Alarmlock



MS-2

Double motorstarter for one or two electro-hydraulic pump units. Complete with amp.meter and emergency stop.

Alarms for:

- Start/stop
- Test
- Power failure
- Low oil
- Overload



Scan-Steering
Excellent Navigation

Rudder control & starters



RC/MS

Double remote control for RC (rudder control) and MS-2 (motorstarter).

Joystick for non-follow-up and rudder indicator.

Facilities for connection of additional rudder indicator and Full-follow-up.

Alarms for:

- Start/stop
- Test
- Power failure
- Low oil
- Overload



RC

Double rudder control with two electrical separated systems for electrical steering and control of up to 4 sets of hydraulic valves.

Each system consist of:

- Rudder indicator
- Switch for bridge/steering room control
- Non-follow-up control of the rudder



Autopilots

SCAN MFA

Versatile compact MED approved speed adaptive autopilot for all class of vessels up to unlimited size. Wheelmark approved (can be class approved by any class society).



- Suitable for single and independent ruddersystems
- Magnetic Sensor Coil Heading Input
- Multi Waypoint Track pilot in combination with ALPHACHART T
- Adaptive / PID steering
- Large TFT info screen
- Integral Off Course Alarm
- Integral Watch Alarm
- Bow thruster and rudder control
- Custom U-Turn & Next Course functions
- NMEA & Furuno Heading Outputs
- 11-40 V DC Power supply
- 11-120 V DC/5A rated solid state switch
- Outputs to Solenoids
- +/- 10 volt output isolated
- Connectable to rudder propellers or water jets
- Also available in black color

SCAN MFC

Versatile compact MED approved speed adaptive autopilot for all class of vessels up to 10.000 GT. Wheelmark approved (can be class approved by any class society).



- Dual NMEA Heading Inputs
- Mag Sensor Coil Heading Input
- Multi Waypoint Track Steering
- Multiple Control unit Options
- Integral Off Course Alarm
- Integral Watch Alarm
- Custom Turn & Dodge functions
- NMEA & Furuno Heading Outputs
- 11-40V DC Power supply
- 11-120 V DC/5A rated solid state switch Outputs to Solenoids
- +/- 10 volt output isolated
- Inclusief high speed version HSC MED wheelmark approval



Scan-Steering
Excellent Navigation

Autopilots

Feature	SCAN MFA	SCAN MFC
11-40V DC Primary supply	1	1
11-40V DC Back-up supply	1	1
HSC2 compass coil	1	1
IEC61162/1 or /2 heading input	3	2
IEC61162/1 or /2 track input	1	1
IEC61162/1 or /2 speed input or 200/400 ppNm pulse input	2x NMEA or 1x NMEA, 1x pulse	2x NMEA or 1x NMEA, 1x pulse
Isolated rudder reference input (Single ended or Sin/Cos)	2	1
Max. number of control units	3	3
Rudder Angle indicator output	2	1
Isolated IEC61162/1 or /2 output	2	2
Furuno AD10 style heading output	1	1
Solenoid output (11-120V DC)	2 (independent)	2 (parallel)
Volt free switch line standby / engaged	1	1
RSC input	2	1
Volt free alarm contacts	3	3
Remote standby input	1	1
Power monitor changeover contact	1	1
Spare (status) digital input/output	1	1
+/- 10V isolated analogue o/p	4	2
4-20mA isolated o/p	4	2
5V step output	1	1
Step heading i/p (5V DC only)	1	X
4-20 mA isolated draft i/p	1	1
Opto-isolated remote power up i/p	1	1
Opto-isolated remote enable i/p	2	1
+/- 10V isolated i/p (FU / HSC spec use)	2	1
Ethernet	2	x



Universal repeaters

All repeaters meet the requirements of IMO & SOLAS



DE-180

Digital repeater operates on NMEA 0183 (RS422 or RS232).



DE-200

Digital repeater/turning indicator can operate on NMEA 0183 (RS422 or RS232), step by step and syncro 360:1 input. The bar graph showing rate of turn.



BRA-250

Steering repeater with tilting bracket. Operates on NMEA 0183 (RS422 or RS232), step by step.

BRB-250

Bearing repeater for bulk-head mounting. Facilities for Azimuth. Operates on NMEA 0183 (RS422 or RS232), step by step.



BRC-250

Bearing repeater on column. Facilities for Azimuth. Operates on NMEA 0183 (RS422 or RS232), step by step.



GFC

Azimuth circle for bearing repeater. Delivered in wooden box



Scan-Steering
Excellent Navigation

Accessory equipment

To be used as part of our complete steering system



RVP-2

Panorama rudder indicator, with dimmer. Improved version.



RXL

Ground-breaking range of panel-mounted illuminated rudder indicators.
Size: 96x96 mm and 192x195 mm



FBP

Electronic rudder angle transmitter with single or double signal. Delivered with longlife potentiometer. Improved version with high accuracy.



V-500m

Watch alarm with switch for 10 or 15 minutes delayed alarm.



STM/STU

STM: Manual pilot operation.
STU: Joystick control.



STS Joystick

With push button to activate steering position.



FFU-2000

Full Follow Up with wheel. Adjustable zero and gain.



FU S-M4970

Full Follow Up with wheel. Green backlight. Size: 96x96 mm



NFU

Hand operated non-follow-up with rudder indicator and 6 m wire.



Gyro Compass



Gyrocompass Mini Course

New gyrocompass “MINI course” is one of the most miniature mechanical gyrocompasses in the world. It is designed to meet the requirements of modern marine industry in wide range of applications due to its high accuracy, short settling time, small size and other attractive features. The gyrocompass is based on the dynamically tuned gyroscope; this accurate sensor provides follow-up speed up to 200°/s.

Gyrocompass provides the following data:

- Heading relative to geographical meridian at the vessel's speed up to 70 knots, latitude up to 80 degrees (up to 90 degrees in Direction Gyro mode), roll and pitch angles up to 45 degrees;
- Rate of turn;
- Operation mode data and failure alarm.

Gyrocompass complies with requirements of IMO A.424(XI) and A.821(19), IEC 945-96, ISO 8728-94 and is type approved by Germanischer Lloyd (can be class approved by any class society)



Scan-Steering
Excellent Navigation

Compasses

made according to ISO, IMO and SOLAS



Magnetic Compass

NS-140A Magnetic compass. 6 inches.
Card diameter 140mm.

NS-150A Magnetic compass. 8 inches.
Card diameter 150mm.

Telescope bearing for table or panel mounting options.

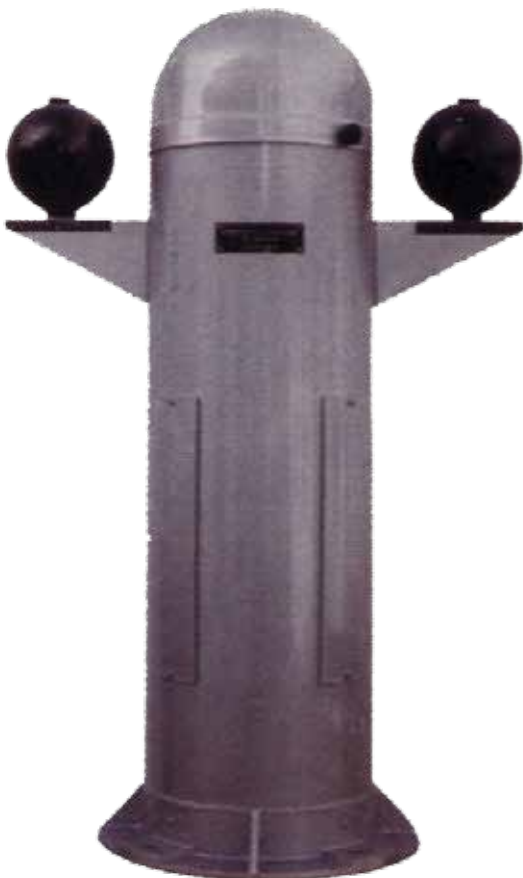

NS-160A Reflector compass

Reflector compass with 505 mm or 1050 mm binnacle. The binnacle is made of seawater resistant aluminium, fitted with a magnetic compass, NS-150A.

- Card diameter 150mm
- Reflector type with mirror and adjustable mirror head
- Main and emergency supply 110/220 V DC



Examples of complete steering systems

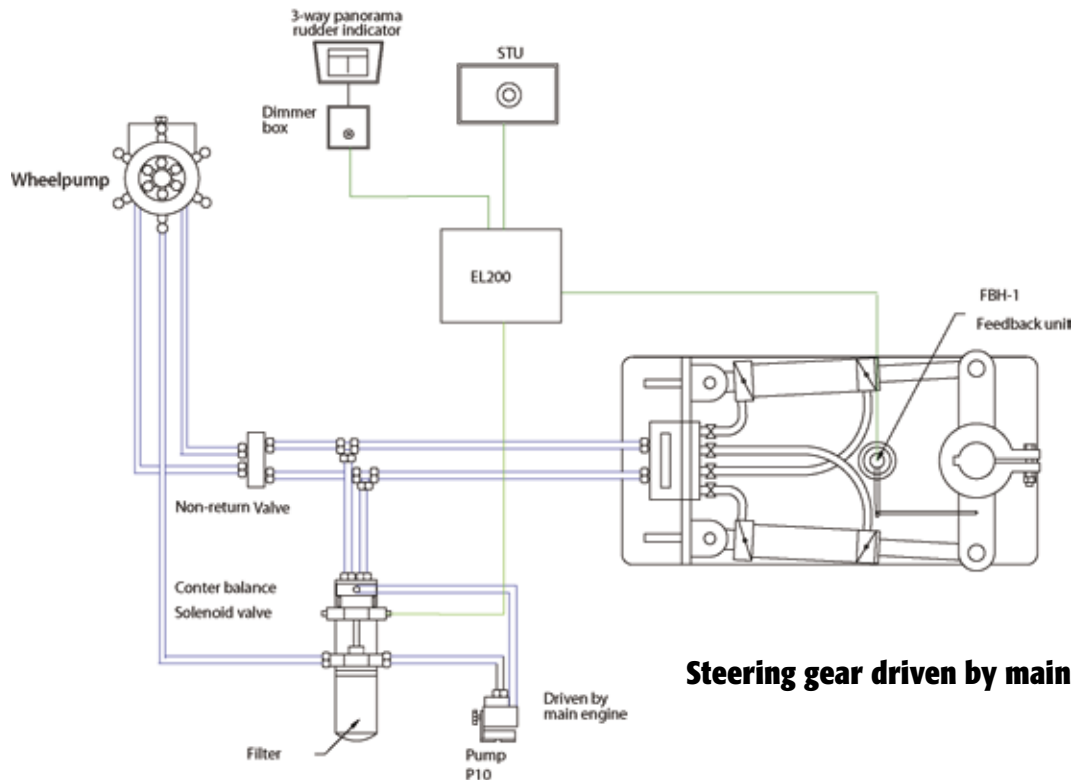

Steering gear driven by main engine

All systems are made according to classification authorities

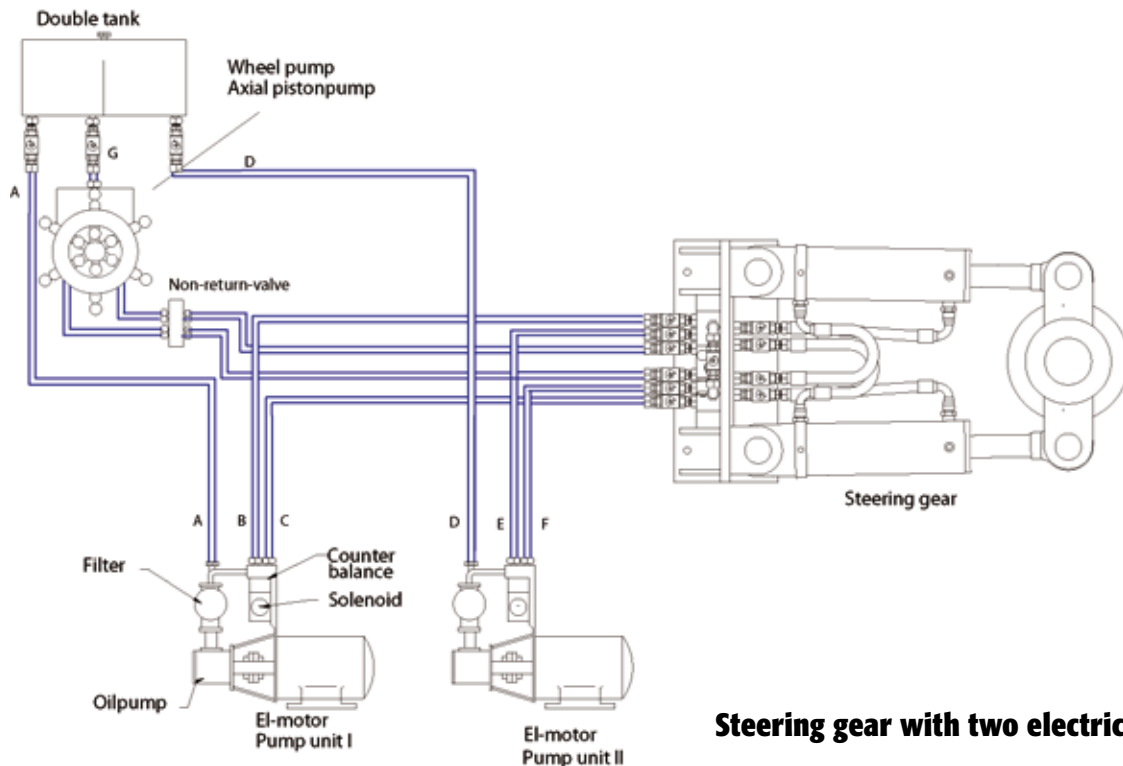

Steering gear with two electrical pumps



Scan-Steering
Excellent Navigation

Examples of complete steering systems

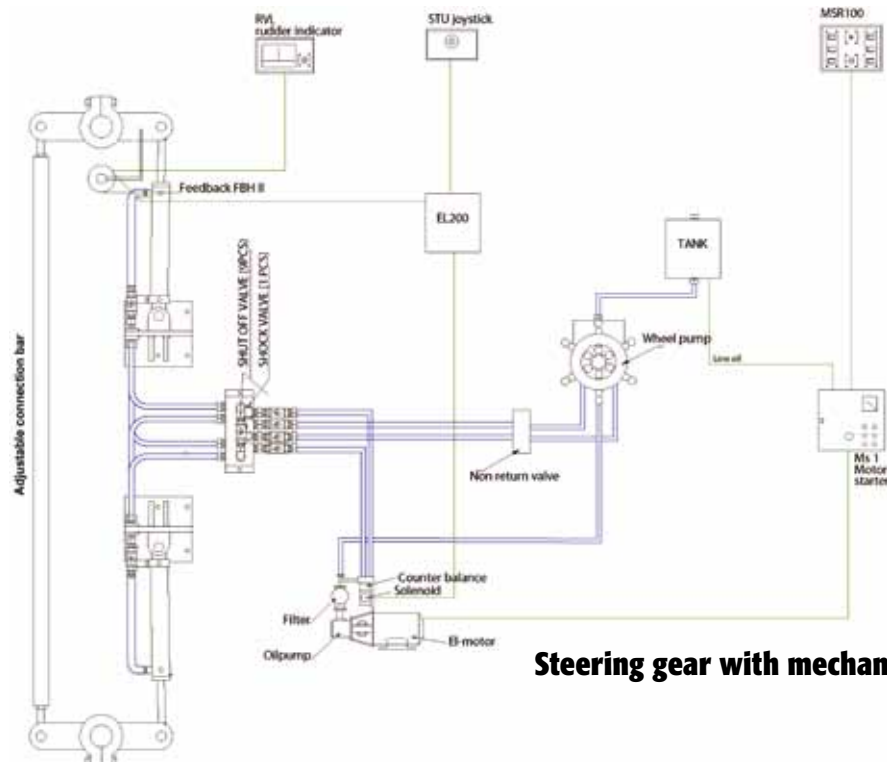

Steering gear with mechanical connection bar

All systems are made according to classification authorities

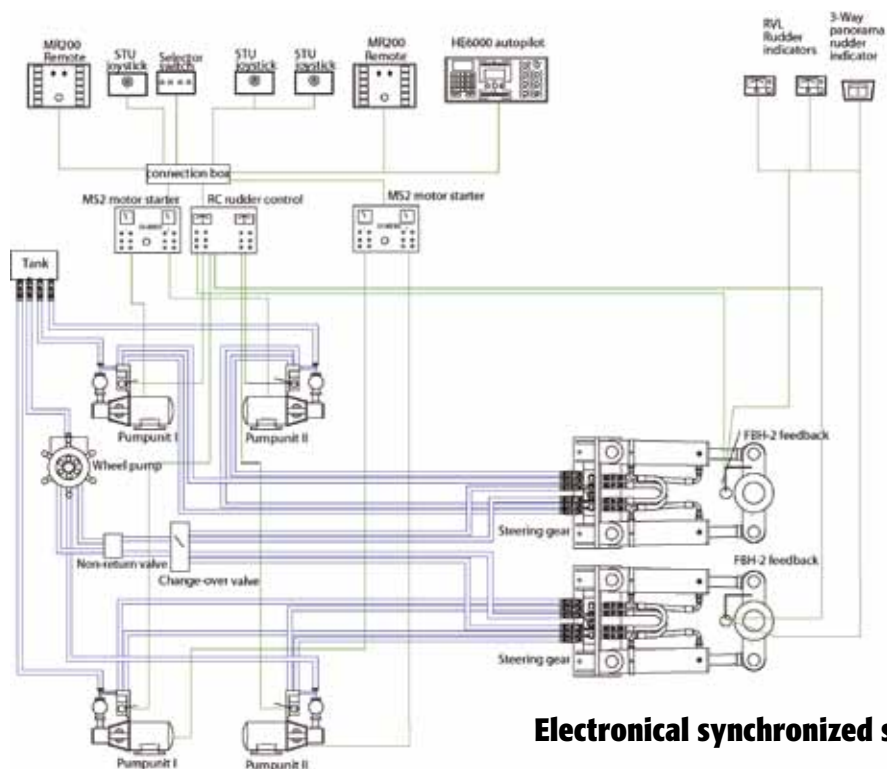

Electronical synchronized steering gear



TOGETHER
we'll compile the steering system
YOU need

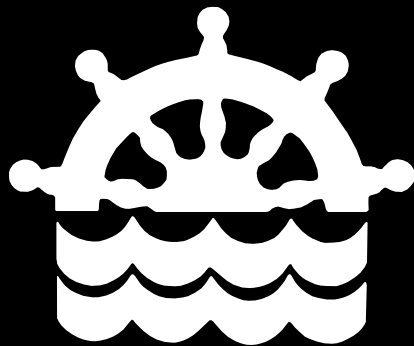

Scan-Steering

Fabriksvej 14 - 6960 Hvide Sande - Denmark

Phone: +45 9731 1045 - Fax: +45 9731 1677

info@as-scan.com - www.as-scan.com

as:scan