

DE200 DIGITAL REPEATER

Operation
and
installation
manual

v4.1 September, 2005

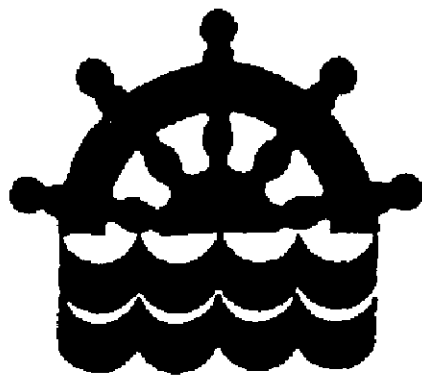

SCAN-STEERING

Table of contents

DE 200 - a brief description.....	3
DE 200 Repeater overview.....	4
Operating DE200 Digital Repeater.....	5
Disassembly.....	6
Configuring.....	7
NMEA 0183 HDT input.....	8
Step Input.....	9
Synchro input.....	10
Force Input selection.....	11
Last Digit on/off.....	12
Rate of Turn Indicator Setup.....	13
Output.....	15
Software Setup Quick reference.....	16
PBC Drawing.....	19
Technical data.....	21
Dimensions.....	22

DE 200 - a brief description.

DE 200 is a digital repeater, designed to withstand the conditions on a ships bridge. The DE 200 is delivered with a bracket for mounting. It is also possible to panel mount the repeater.

The repeater is provided with large red illuminated digit for clear long distance course reading and a red LED bar for indication of Rate of Turn.

The DE 200 repeater only needs 24Vdc power and a NMEA 0183 (RS422/RS232), Step by Step (6/12 step/deg.) or synchro (360:1) signal.

Furthermore the DE200 digital repeater will produce a NMEA0183 RS422 HDT output from the input signal.

DE 200 Repeater overview.

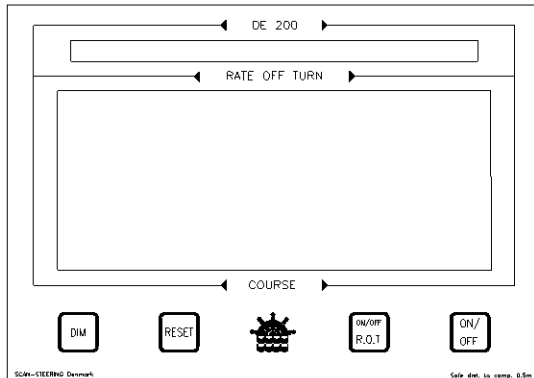

Fig. 1

DIMMER

The [DIM] button is located on the front of the DE 200 digital repeater. It is possible to dim the DE 200 repeater to 7 different levels of light intensity.

RESET

The [RESET] button is located on the front of the DE 200 digital repeater. The [RESET] button is used for adjusting course when using step by step or synchro as input signal.

ON/OFF R.O.T

The [ON/OFF R.O.T] button is located on the front of the DE 200 digital repeater. The [ON/OFF R.O.T] button is used for turning on and off the LED's in the Rate of Turn bar.

ON/OFF

The [ON/OFF] button is located on the front of the DE 200 digital repeater and is used for turning the DE 200 digital repeater on and off.

OPERATING DE200 DIGITAL REPEATER

Normal operation of the DE200 repeater, is very simple and easy.

When the repeater is connected to synchro or step input, it is possible that the repeater does not show the correct course, (e.g. if the repeater was turned off), to get the repeater to show the correct course, press [RESET] now the course will increase, first slowly, and then after a few seconds, faster, until the right course is reached.

In case the Rate of Turn indication is unwanted, it is possible to disabled it completely by pressing the [ROT ON/OFF] button, this button will enable or disable the Rate of Turn indication.

To dim the course and RoT indicators press [DIM], each time the [DIM] button is pressed, the intensity of the indicators will decrease, there are 7 levels of intensity. When at the least intensive level and [DIM] is pressed, the repeater will go back to the most intensive level.

Turning the repeater on and off, is done using the [ON/OFF] button, be aware, that if the repeater is connected to step or synchro input, it is possible that the repeater will not show the correct course after been turned off, therefore in this case the repeater should not be turned off at any time. If the repeater is connected with serial NMEA input, the repeater can safely be turned off and on and still show the correct course.

Disassembly

The DE200 is assembled with 4 screws, look at drawing, loosen these four screws, then it is possible to remove the front of the repeater. When the repeater is open, there is access to the connection terminals (Fig 3, page 18).

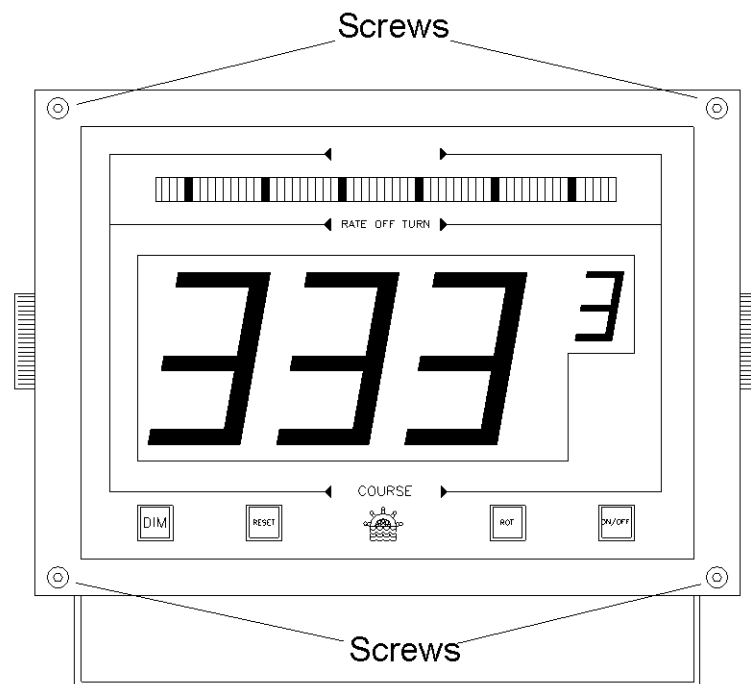

Configuration.

All setups except NMEA RS232 / RS422 are done in software, when software setups have been made and saved it will stay in the repeaters memory even if the repeater is turned off or the power is removed. All software setups are described in the following chapters.

Setup's are :

NMEA0183, RS422 or RS232	(only needed if connected to NMEA RS232) (factory setting is RS422)
STEP 6 or 12 step/degree	(only needed if connected to 12 step/deg.) (factory setting is 6 step/deg.)
Synchro synchronization	(only needed if problems with synchro input) (repeater will autodetect when connected to synchro input)
Force input selection	(only needed if problems with detection of input) (factory setting is 0=autodetect)
Last digit on/off	(only needed if you want to disable the last digit) (factory setting is last digit on)
Rate of Turn indicator	(adjustment of sensitivity of ROT indicator) (factory setting is mode1 high sensitivity)

Configuring Input signals.

The DE-200 repeater **automatically** detects the connected type of input signal, this means that no setup is necessary for selecting input signal, just connect the signal (NMEA, Step or Synchro) turn on the repeater, then the repeater will detect the signal.

NMEA signals has the highest priority (NMEA, Step or Synchro). If NMEA HDT is available this signal should always be used, because of easy installation e.g. only 2 cables for installation, repeater will be self adjusting.

NMEA 0183 (RS422 or RS232) HDT INPUT

The DE200 Digital repeater can be configured for using NMEA0183 RS232 or RS422 input. This is done by setting the DIPSWITCH on the pcb. Look at fig.2 for settings, fig.3 page 18 for location of dip-switch.

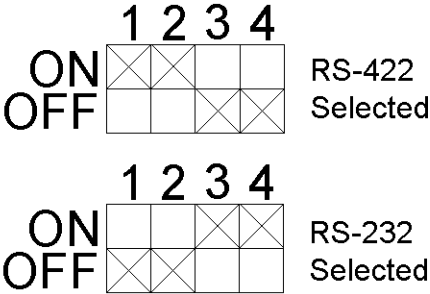

Fig.2

The sentence accepted by the repeater is NMEA0183 v2.0 :

```
$xxHDT,xxx.x,T<CR><LF>
```

The NMEA serial input is connected to the NMEA IN terminals. (fig. 3, page 18)

STEP INPUT

When using step input, a setup has to be done, selecting 6 or 12 step/degree. To enter the setup for step input :

Press [DIM] and [ROT ON/OFF] simultaneous. (Entering setup)

The Rate of Turn (ROT) indicator will show :



Display will show :

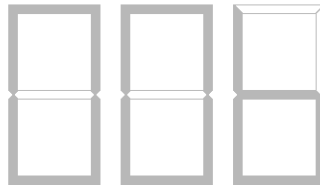

or

Now you can

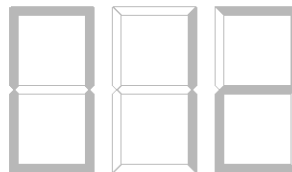

choose between 6 and 12 Step/Deg.

by pressing [ON/OFF ROT], when selection has been made press [RESET]

Now the repeater will return to normal operation, using the selected input.

NOTE : You can always exit the setup by pressing [RESET].

When you have selected the appropriate step ratio, you need to adjust the repeater. This is done by pressing [RESET] until you read the correct course in the repeater.

Step input is connected to the STEP / SYNCHRO TERMINALS (fig. 3, page 18):

STEP1	:	S1
STEP2	:	S2
STEP3	:	S3
REF (NEG)	:	R1
REF (POS)	:	R2

Step voltage : 15 - 90 Vdc.

SYNCHRO INPUT

The repeater will accept synchro input ratio 360:1.

When connecting the repeater with synchro input, the repeater will try automatically to calculate the frequency of the synchro input, and from that frequency it will calculate a synchronization delay, but in case this synchronization delay is not precise (the repeater jumps between two courses e.g. 234.7 and 234.8) it is possible to manual adjust the synchronization delay.

To manual adjust the synchronization delay :

Press [DIM] and [ROT ON/OFF] simultaneous. (Entering setup)

The Rate of Turn (ROT) indicator will show :



Now press [DIM], the ROT indicator will show :



Now you can choose the synchronization delay by pressing [ON/OFF ROT]
You can now choose a delay between 5 and 50, the delay will increase by 5 each time you press [ON/OFF ROT].

Normally you should choose 5 for 400Hz synchro and around 40 for 50Hz synchro.

When the selection has been made, press [RESET] to save the setting and exit to normal repeater mode.

Synchro is connected to the STEP / SYNCHRO TERMINALS (fig. 3, page 18):

S1	:	S1
S2	:	S2
S3	:	S3
R1	:	R1
R2	:	R2

Synchro Voltage 15 - 115 Vac / 50 - 400 Hz.

Note that synchro-voltage between S1-S2-S3 must rise to more than half the voltage on reference R1-R2.

FORCE INPUT SELECTION

Normally the DE200 repeater will autodetect the type of input signal connected, but it is possible to force type of input :

Press [DIM] and [ROT ON/OFF] simultaneous. (Entering setup)

The Rate of Turn (ROT) indicator will show :



Now press [DIM] twice, the ROT indicator will show :



Using [ROT ON/OFF] you can choose between (shown in course display) :

0	:	Autodetect
1	:	NMEA0183
2	:	Step
3	:	Synchro 360:1

When selection has been made, press [RESET] to save.

Note : In case the repeater is not receiving any input signal, the digits will be flashing.

LAST DIGIT ON/OFF

In case 0.1 degree accuracy is not needed, eg. on smaller ships, it is possible to disable the last digit :

Press [DIM] and [ROT ON/OFF] simultaneous. (Entering setup)

The Rate of Turn (ROT) indicator will show :



Now press [DIM] three times, the ROT indicator will show :



Using [ON/OFF ROT] you can select (shown in course display) :

0	:	Last digit off
1	:	Last digit on

Press [RESET] to save and exit

RATE OF TURN INDICATOR SETUP

There are 2 different ways (modes) the DE200 repeater will show the ROT.

The first one is a bar starting in mid position, and then goes to starboard or port, depending on vessels turning direction, the length of the bar indicates the turning speed, like shown on drawing :



In this mode (mode 1), there are 3 different adjustments for sensitivity :

- 1 : each Led indicates 1 deg/min. full scale equals 30 deg/min
- 2 : each Led indicates 3 deg/min. full scale equals 90 deg/min
- 3 : each Led indicates 5 deg/min. full scale equals 150 deg/min

Sensitivity 1 is for slow turning vessels, 3 is for fast turning vessels



In mode 2 the repeater will show 6 led's running to starboard or port, shown on drawing below, depending on vessels turning direction. The running speed of the leds depends on the turning speed of the vessel.

In this mode, there also are 3 sensitivity adjustments :

- 1 : 1 deg/min. per move. Large Vessel
- 2 : 3 deg/min. per move.
- 3 : 5 deg/min. per move. Small Vessel

Sensitivity 1 is for slow turning vessels, 3 is for fast turning vessels

To setup the ROT indicator press [DIM] and [ROT ON/OFF] simultaneously (enter setup). ROT indicator will show :

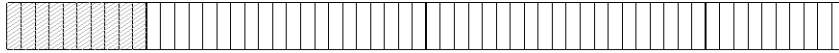

Now press [DIM] four times, until the RoT indicator shows :



Now it is possible to select mode using the [ROT ON/OFF] button, possible modes are (shown in course display) :

- 1 : Mode 1, sensitivity 1
- 2 : Mode 1, sensitivity 2
- 3 : Mode 1, sensitivity 3
- 4 : Mode 2, sensitivity 1
- 5 : Mode 2, sensitivity 2
- 6 : Mode 2, sensitivity 3

When the desired mode has been selected, press [RESET] to save settings and exit setup.

OUTPUT FROM THE REPEATER

The DE200 digital repeater will produce a RS422 NMEA0183 output, from the input signal, the format of the output is :

```
$HEHDT,xxx.x,T<CR><LF>
```

Where xxx.x is the course in the display of the repeater, eg. 312.4 degrees.

This output makes the DE200 repeater very suitable for use as an interface (Step to NMEA or Synchro to NMEA) for autopilots, radars etc.

SOFTWARE SETUP QUICK REFERENCE

General description of keyboard functions in setup

Enter setup :

Press [DIM] and [ROT ON/OFF] simultaneous

Select what to setup :

Press [DIM] to move to the next option

Select setting :

Press [ROT ON/OFF]

Confirm setting and exit

Press [RESET]

SOFTWARE SETUP OVERVIEW

STEP : 6 / 12 step/degree input.

Press [DIM] and [ROT ON/OFF] simultaneous



Press [ON/OFF ROT] to select 6 or 12 step/degree.

Press [RESET] to save and exit.

Synchro : Synchronization delay

Press [DIM] and [ROT ON/OFF]

Press [DIM]

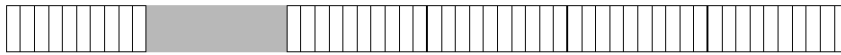

Select using [ON/OFF ROT] : 5 - 50

Press [RESET] to save and exit.

Forced input selection

Press [DIM] and [ROT ON/OFF]

Press [DIM] twice

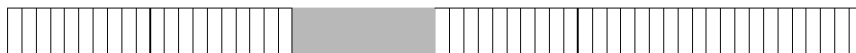

Select using [ON/OFF ROT] :

- | | | |
|---|---|---------------|
| 0 | : | Autodetect |
| 1 | : | NMEA0183 |
| 2 | : | Step |
| 3 | : | Synchro 360:1 |

Press [RESET] to save and exit.

Last Digit ON/OFF

Press [DIM] and [ROT ON/OFF] simultaneous.

Now press [DIM] three times, the ROT indicator will show :



Using [ON/OFF ROT] you can select :

0	:	Last digit off
1	:	Last digit on

Press [RESET] to save and exit

Rate of Turn indicator setup:

Press [DIM] and [ROT ON/OFF] simultaneous.

Now press [DIM] three times, the ROT indicator will show :



Select using the [ROT ON/OFF] button

1	:	Mode 1, sensitivity 1
2	:	Mode 1, sensitivity 2
3	:	Mode 1, sensitivity 3
4	:	Mode 2, sensitivity 1
5	:	Mode 2, sensitivity 2
6	:	Mode 2, sensitivity 3

Press [RESET] to save and exit.

PCB Drawings

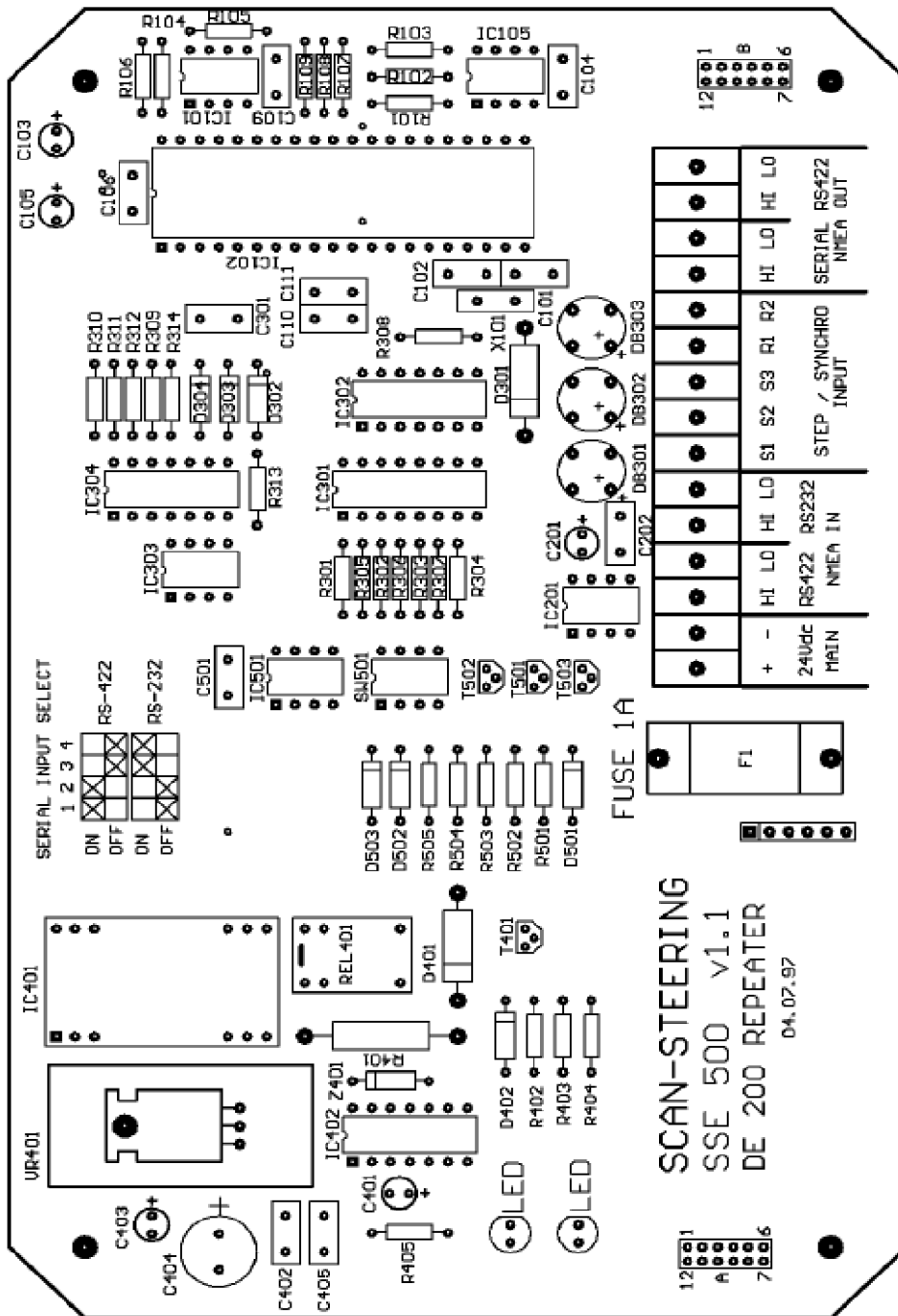

SSE 500, Fig. 3

PCB Drawing

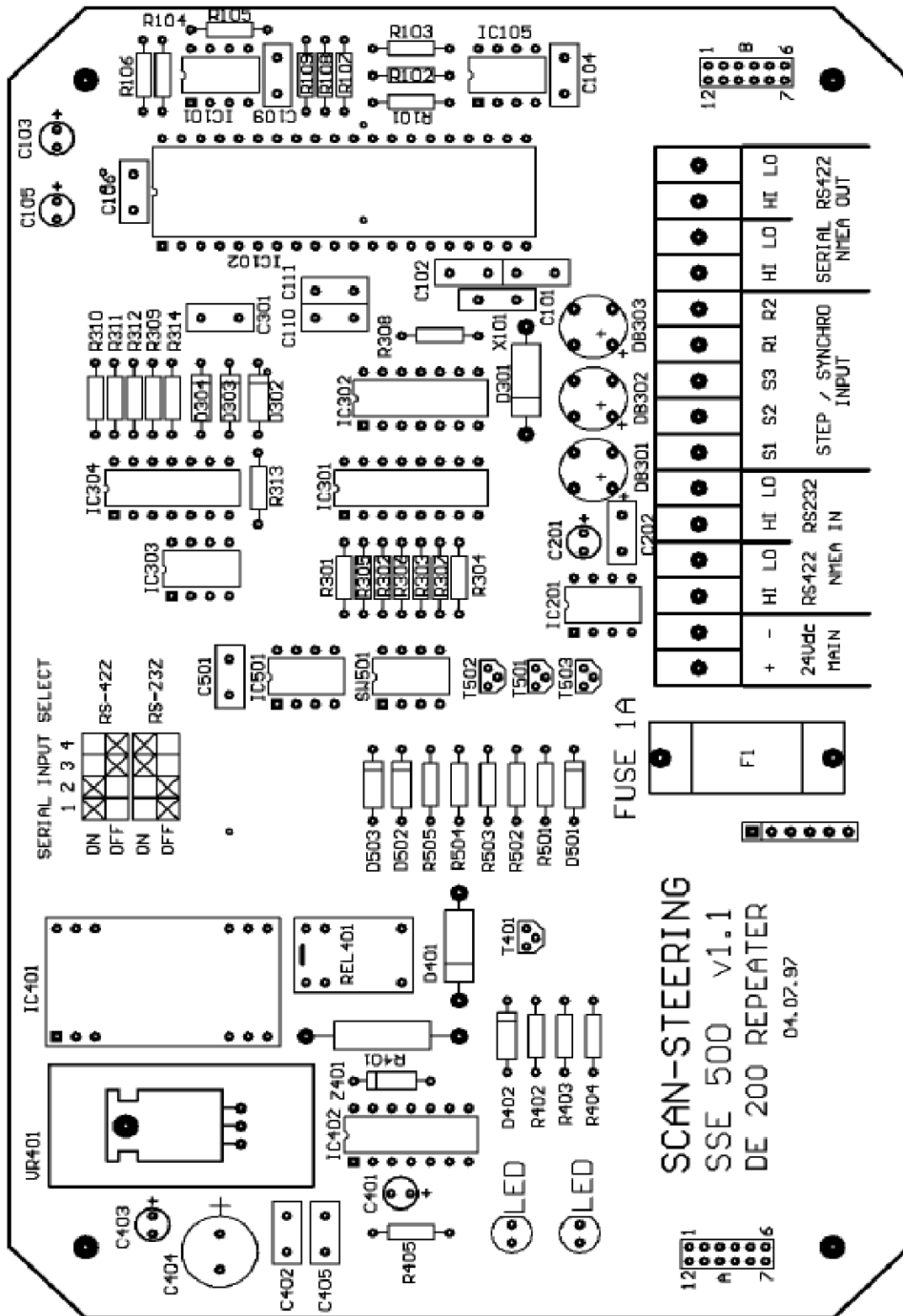

SSE 510, Fig. 4

Technical data

Input signal: NMEA0183 RS232 or RS422
\$xxHDT,xxx.x,T<CR><LF>

Step by Step (6 or 12 Step/Degree)
Positive or Negative Reference, 15 - 90Vdc.

Synchro 360:1 (15-115Vac / 50-400 Hz)

Accuracy:	NMEA 0183	:	0.1 deg.
	Step (6 step/degree)	:	0.2 deg.
	Step (12 step/degree)	:	0.1 deg.
	Synchro (360:1)	:	0.2 deg.

Power input: 18 - 36 Vdc

Power consumption Max 7.5W.

Fuse: 315mA fuse (fig.3 shows location)

Dimensions

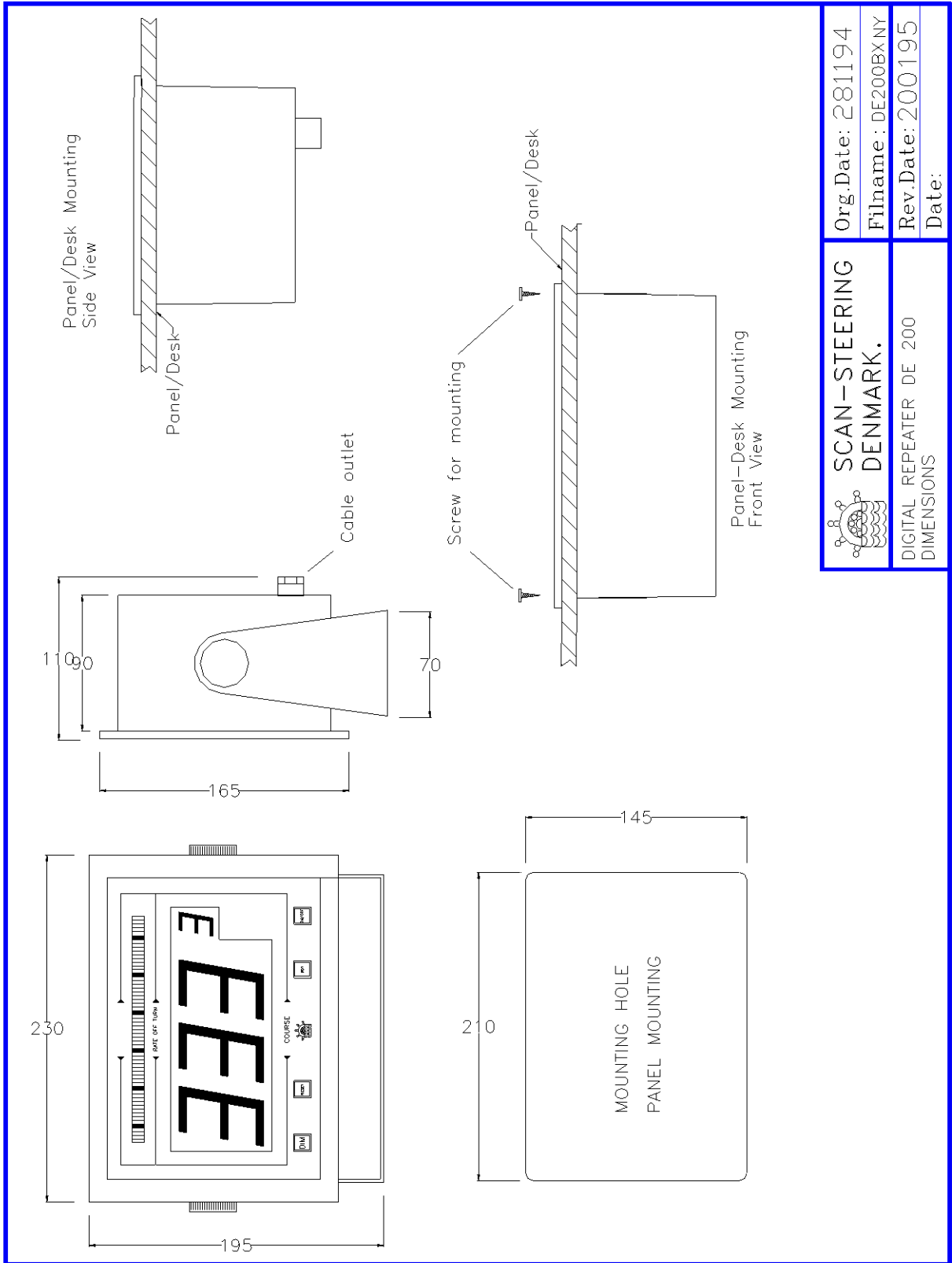

 SCAN-STEERING DENMARK.	Org.Date: 281194
	Filename: DE200BXNY
DIGITAL REPEATER DE 200 DIMENSIONS	Rev.Date: 200195
	Date: