

Data sheet for FBH-1/2



FBH-1 & FBH-2 are two high technological rudder feed backs. Special made to operate onboard ships of all kinds and sizes. The rudder feed backs are remarkable in there construction, as there are made with any mechanical parts that can be wear out.

The FBH-1 & FBH-2 can be split up into two half.

- The Sensor module that is the mechanical part, mounted on the rudder system.
- The amplifier module that is the electronic part, and transmit the signal to indicators, autopilots etc.

Data specifications

Parameter	FBH-1	FBH-2	Unit
No. of outputs	1	2	pcs.
Supply voltages	7 - 10	7 - 10	Vdc
Supply current	< 300	< 300 (each)	mA
Output ranges $V_{supply} = 8Vdc$	0.75 - 7.25	0.75 - 7.25	max Vdc
Max degrees	45 - 0 - 45	45 - 0 - 45	degrees
Zero adj. possibility?	Yes	Yes	
Gain adj. possibility?	Yes	Yes	
Galvanic separated outputs?	-	Yes	
No. of amplifier box	1	2	pcs.

Measures

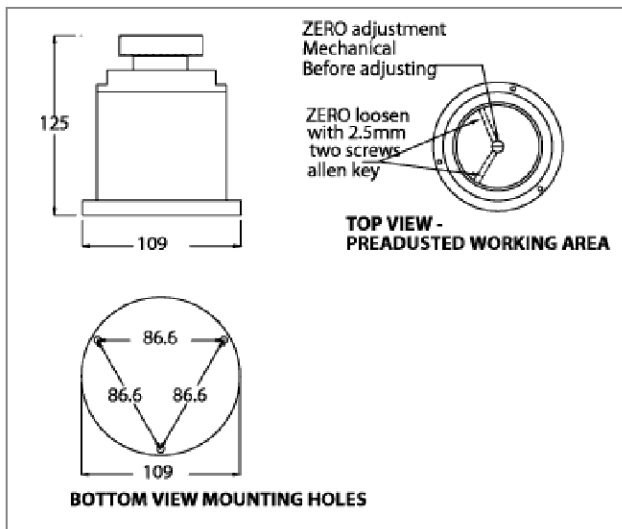

Sensor module

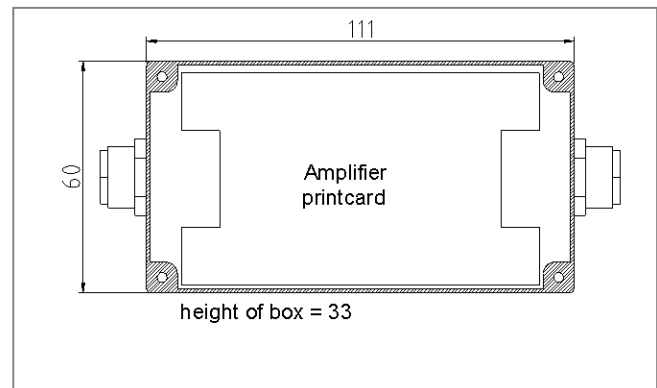

Amplifier module